

PARÇA KODU PART CODE	PARÇA ADI PART NAME	s ÖLÇÜSÜ (KALINLIK) s MEASURE (THICKNESS)	Malzeme Material	Kaplama / Coating		
				SN	AG	Nİ
TŞ 2417 DP	2.5 NO KABLO UÇ B.A.Ø4.2 =DP=	0.45±0.05	(CuZn30) Pirinç / Brass	-	-	-
TŞ 2417 RP	2.5 NO KABLO UÇ B.A.Ø4.2 =RP=	0.45±0.05	(CuZn30) Pirinç / Brass	-	-	-
TŞ 2417 RPK	2.5 NO KABLO UÇ B.A.Ø4.2 =RPK=	0.45±0.05	(CuZn30) Pirinç / Brass	+	-	-
TŞ 2417 RÇN	2.5 NO KABLO UÇ B.A.Ø4.2 =RÇN=	0.50±0.05	Nikel kaplı çelik / Nickel plated Steel	-	-	+
TŞ 2417.50 RP	2.5 NO KABLO UÇ B.A.Ø4.2 =RP=	0.50±0.05	(CuZn30) Pirinç / Brass	-	-	-
TŞ 2417.50 RPK	2.5 NO KABLO UÇ B.A.Ø4.2 =RPK=	0.50±0.05	(CuZn30) Pirinç / Brass	+	-	-

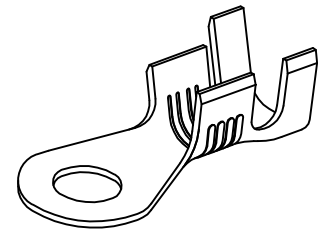
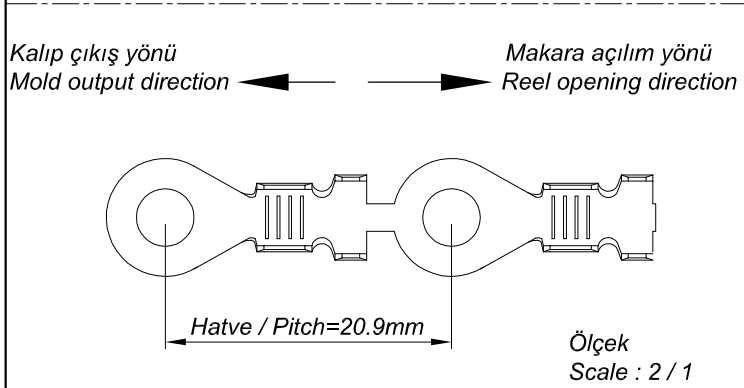
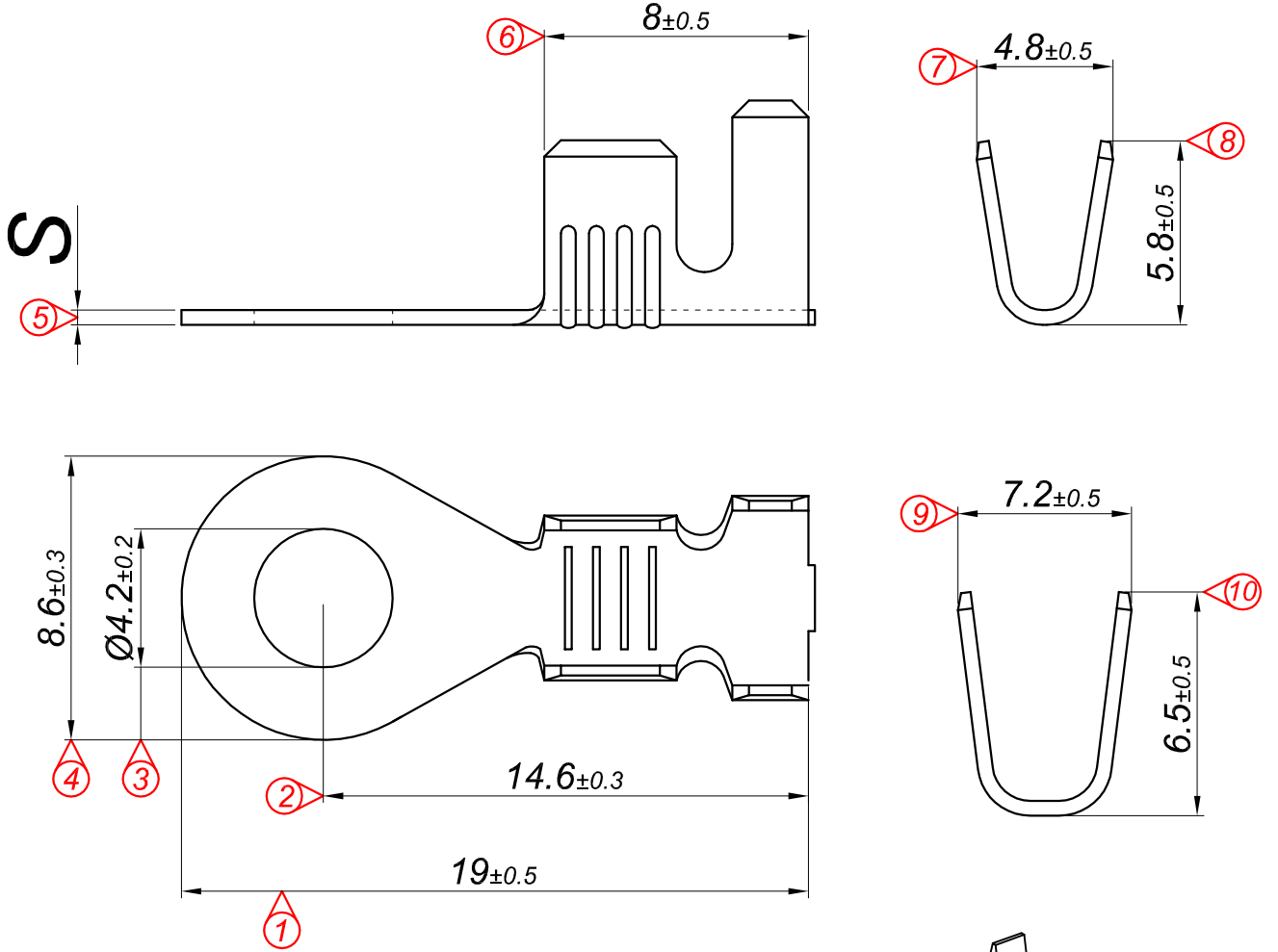

Kablo Kesiti  
Wire Section : 2.50 - 6 mm<sup>2</sup>

Resim üzerinden ölçü almayınız  
do not measure on drawing

Tarih / Date	19.07.2013	İmza /Signature	Ölçek /Scale			
Çizen / Desing	M.Yağcı		5 / 1	01	Çiftli kalıp yapılmıştır, Ölçüler yeniden düzenlenmiştir.	03.04.2015
Onay / Approval	S.Gölcük			No	Değişiklik / Revision	Tarih/Date



Parça Adı:  
Part Name

2.5 NO KABLO UCU  
BÜYÜK AYAK Ø4.2

Parça Kodu:  
Part Code

TŞ 2417